

General Information

The WW Heat Pump Water Heater recovers waste or unwanted heat from a *source* such as building chiller loops, warm water from water cooled condensers, geothermal loops and a variety of other *sources*. The hot water generated by the WW Heat Pump, supplies a storage tank and can be used as potable or process hot water. The WW-190 Heat Pump is right for many large size commercial and condominium applications. When options such as built-in pumps are included, the installation becomes fast and easy; just connect the water and electrical power and the system is on line.

General Specifications

- Water Heating Capacity *: 192,000 BTUH
- Cooling Capacity *: 138,000 BTUH
- COP *: 3.5
- Source Water Flow Rate: 39 GPM
- Supply Water Flow Rate 30 GPM (Hot Water)

Standard Features

- High Efficiency Scroll Compressors(2)
- Environmentally Friendly Refrigerant: R-134a
- Stainless Steel Brazed Plate Double Wall Condenser
- Stainless Steel Brazed Plate Single Wall Evaporator
- Liquid Line Filter Dryer
- Liquid Line Sight Glass
- Thermal Expansion Valve
- Evaporator Freeze Protection
- High and Low Refrigerant Pressure Switches
- Flow Switches
- Control Function Indicator Lamps
- White Pre-Painted Aluminum Cabinet

Options

- Stainless Steel Cabinet
- Mill Finished Aluminum Cabinet
- Stainless Steel Brazed Plate Single Wall Condenser
- Reverse Acting Source Water Control Valve for operating with Excessive Source Water Temperature
- Compressor Run Hour Meter
- Shell and Tube, or Tube-In-Tube Heat Exchangers Available on Special Order. Consult Factory.
- Built-In Pump(s)

* EWT 100°F (Entering Supply Water Temperature) and ESWT 70°F (Entering Source Water Temperature)

Electrical Characteristics

Model	Compressor (each)					MCA	MFS
	Volts	Hz	Ph	RLA	LRA		
WW-190 HTC	208/230	60	3	38.2	232	68	90
WW-190 HTD	460	60	3	18.6	125	35	45

MCA= Minimum Circuit Ampacity MFS=Maximum Fuse

(Performance Curves and Dimensional Data pg 2 & 3)

Performance Curves

**WW-190 HT
Capacity vs. Inlet Water**

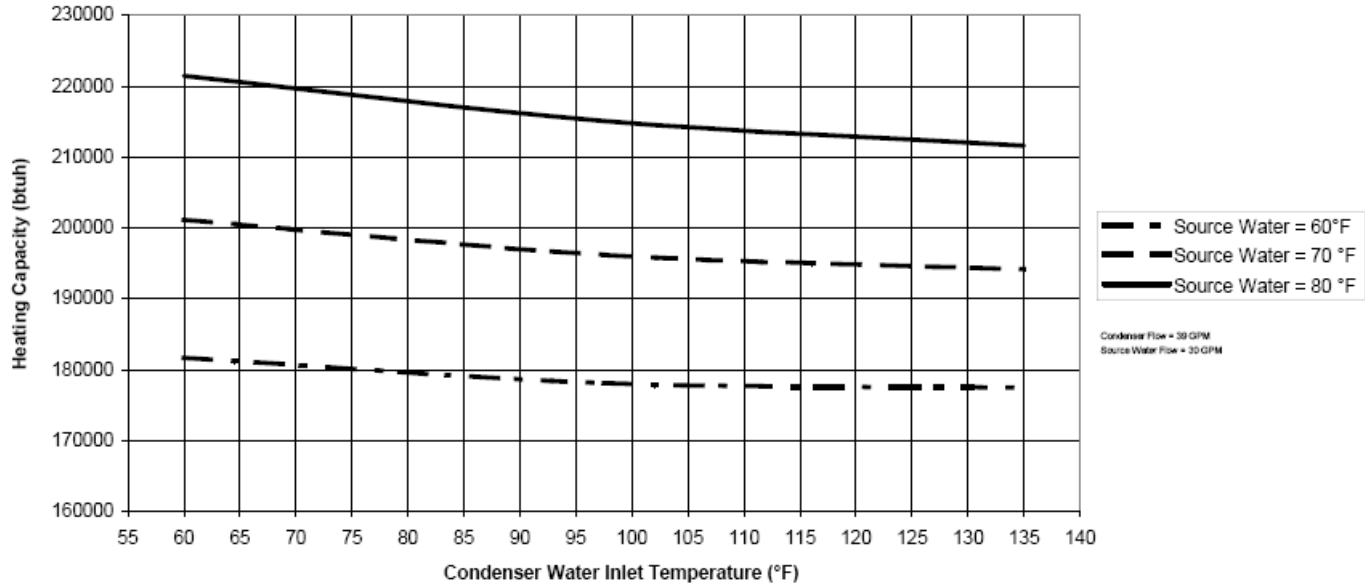

**WW-190 HT
COP vs. Inlet Water**

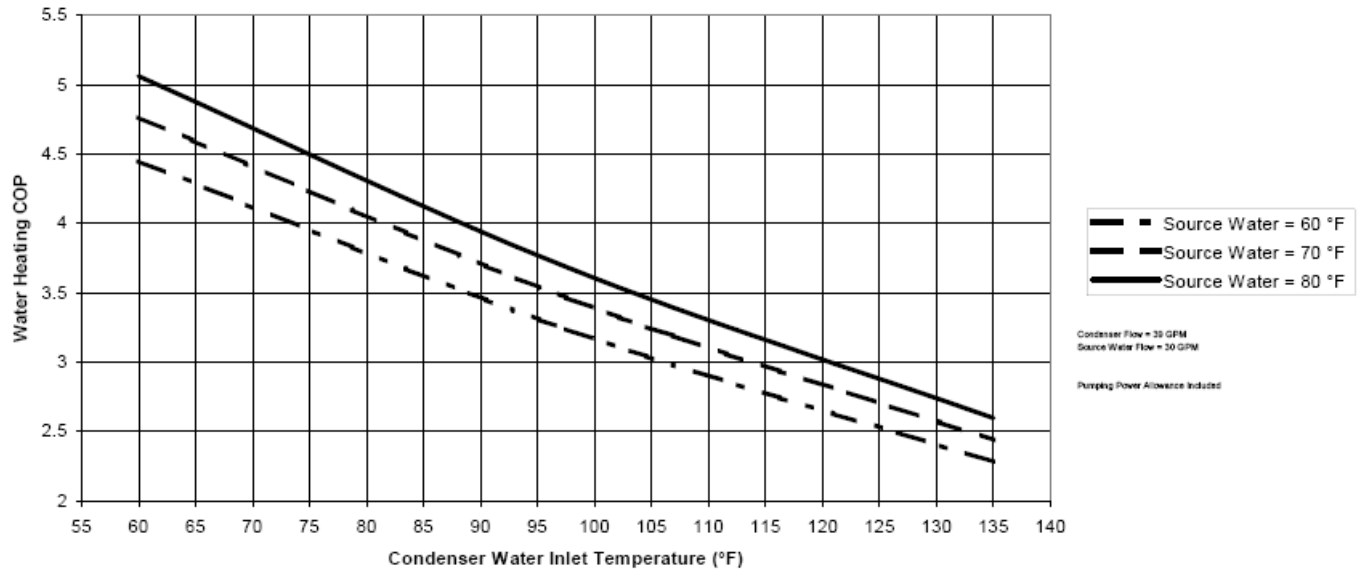

WW-190 HT Dimensional Data

NOTE:
Upper water connections may vary some depending on heat exchanger manufacturing variances.

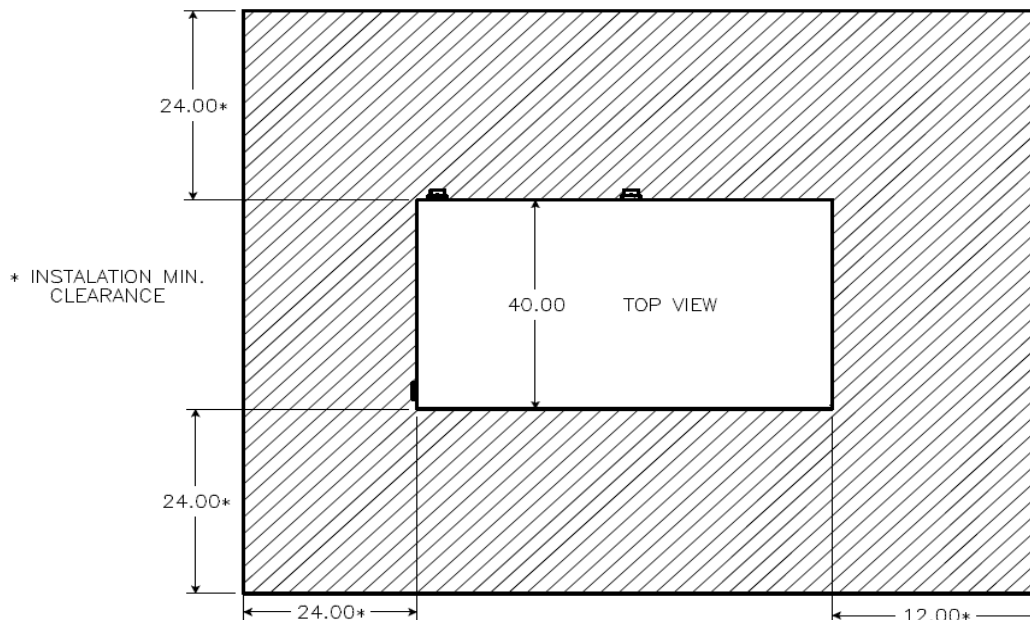
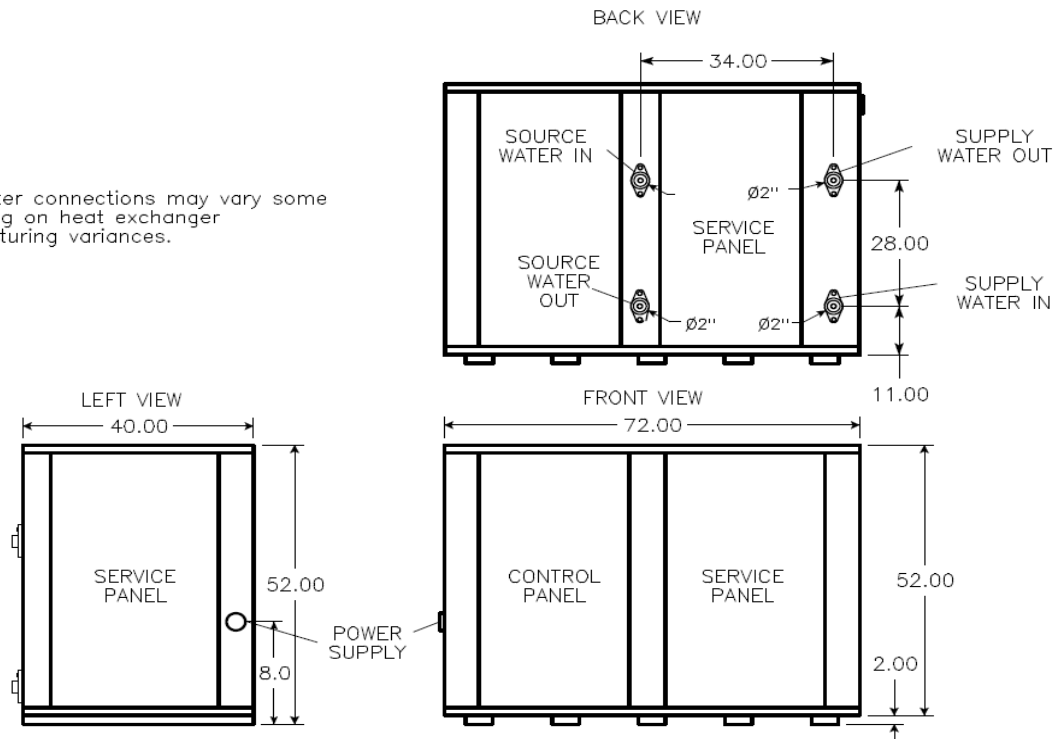

Ship Weight: 920 Lbs.

WW Connection Methods 020513050100

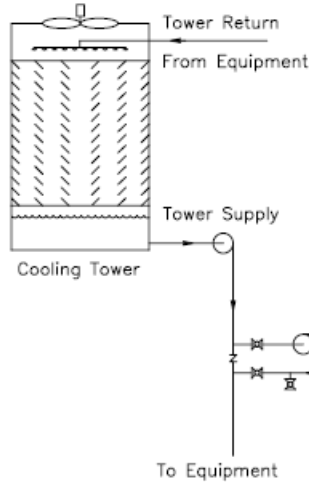

Preferred Connection Scheme:
Source water from tower supply. This water cooler than tower return, but temperature is more constant and stable operation easier to maintain. Directly reduces tower loading.

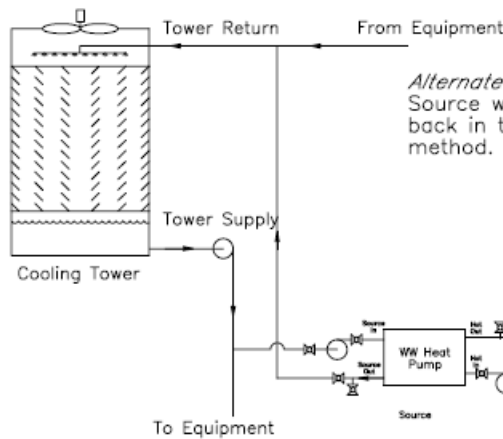

Alternate Connection Scheme #1:
Source water from tower supply. Source outlet put back in tower return. Same benefits as preferred method.

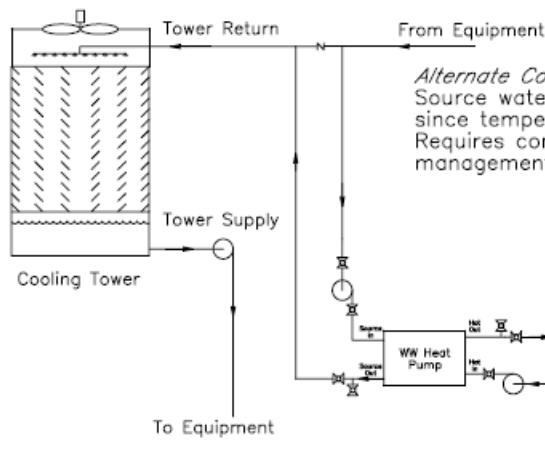

Alternate Connection Scheme #2:
Source water from tower return. Least desirable since temperature fluctuates with tower load. Requires constant source water flow rate management to keep from overloading heat pump.

As part of the Applied Energy Systems, Inc. continuous improvement program, specifications subject to change without notice.